

(Max.60mm)

X	Vesa 200x200	Vesa 400x400
24"	40	
26"	40	
32"	50	
37"	35	25
40"	54.5	29.5
42"	52.5	27.5
46"		41.5
47"		46
52"		45.5

Note Orientation

Figures suggested for reference & variation applied subject to actual conditions varied.

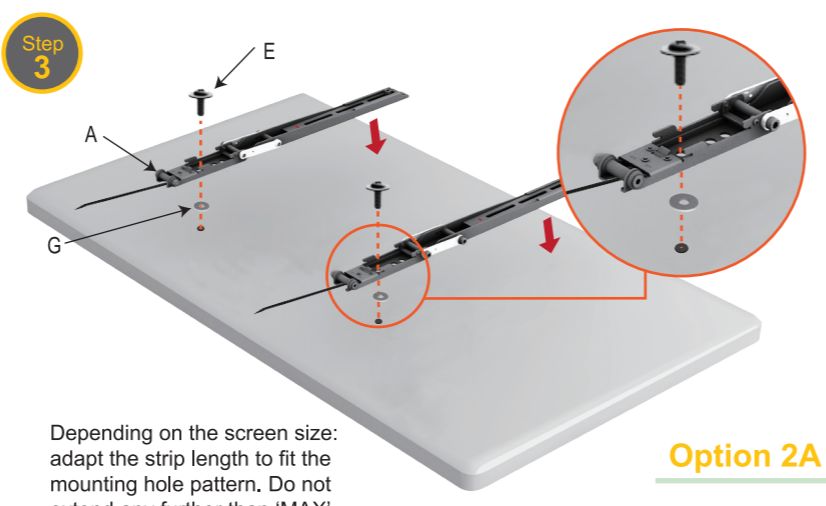

Depending on the screen size: adapt the strip length to fit the mounting hole pattern. Do not extend any further than 'MAX'.

Option 2A

Option 2B

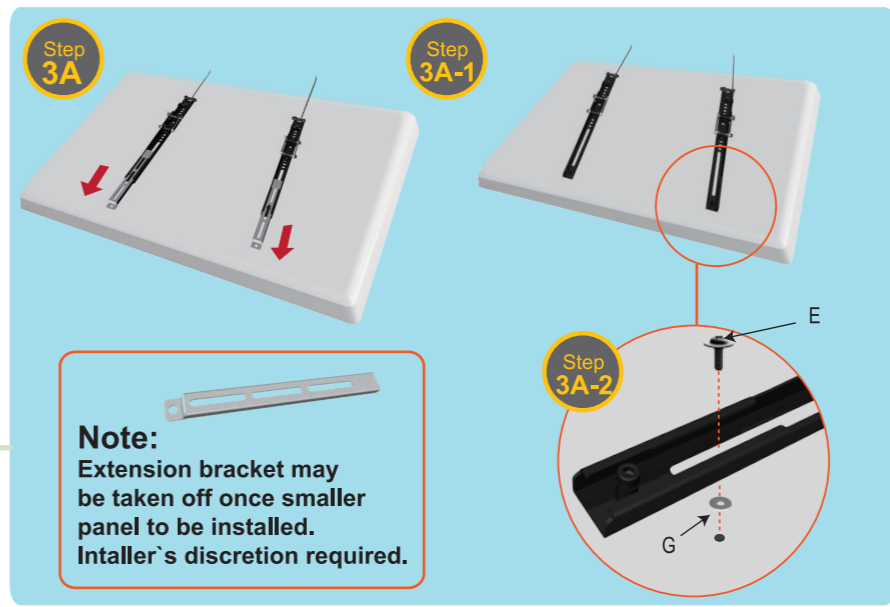

Note: Extension bracket may be taken off once smaller panel to be installed. Installer's discretion required.

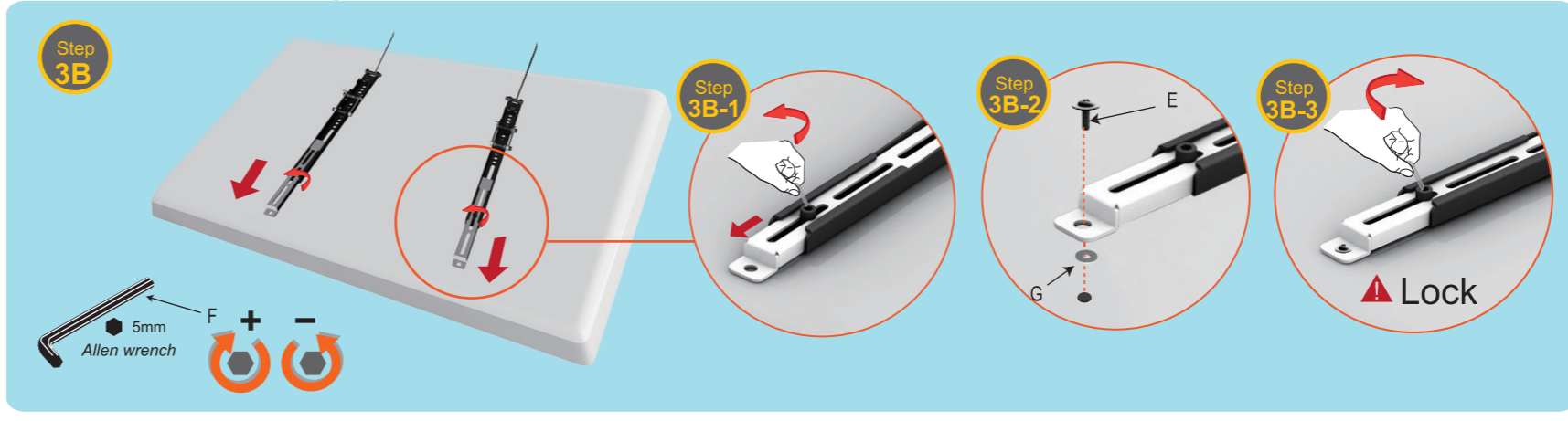

Lock

Torque Adjust

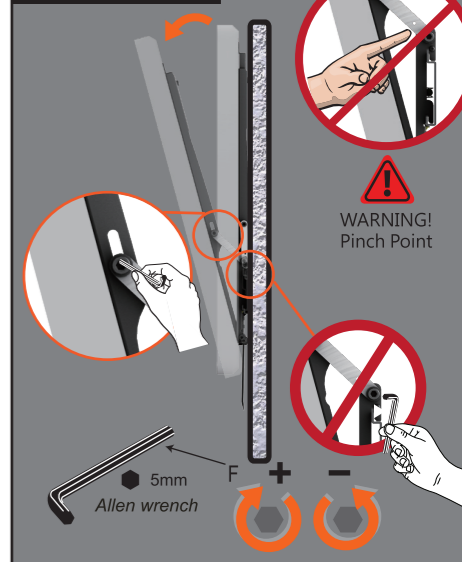

Tilt

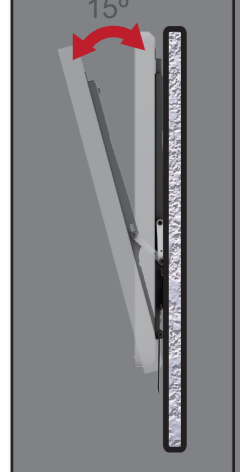

Ultra Slim



102mm

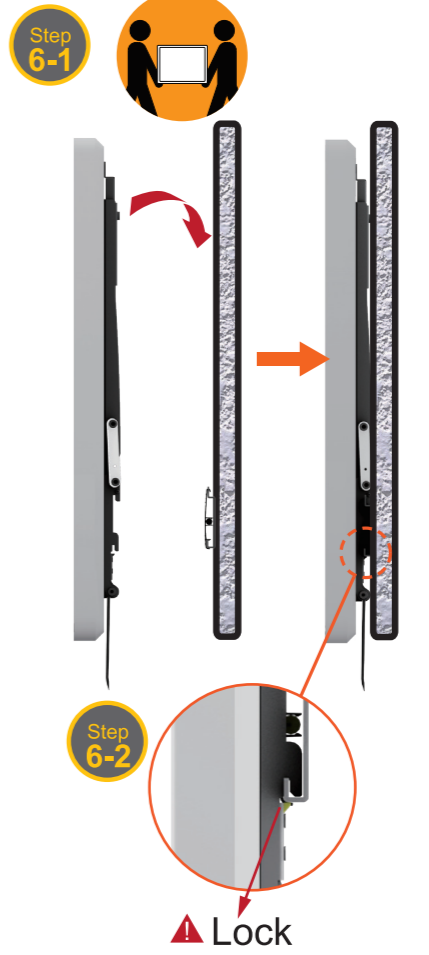
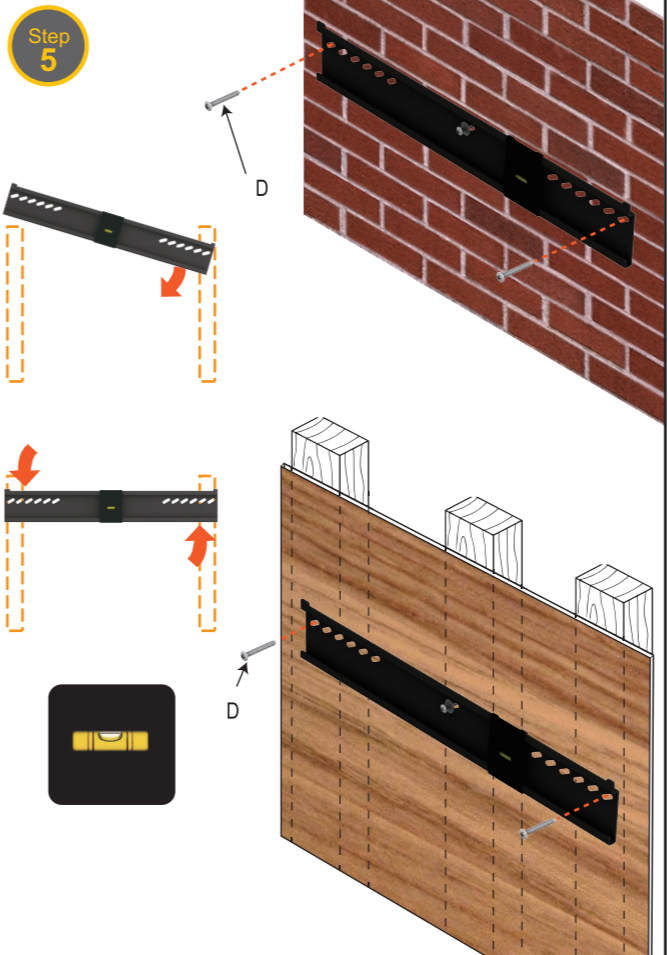
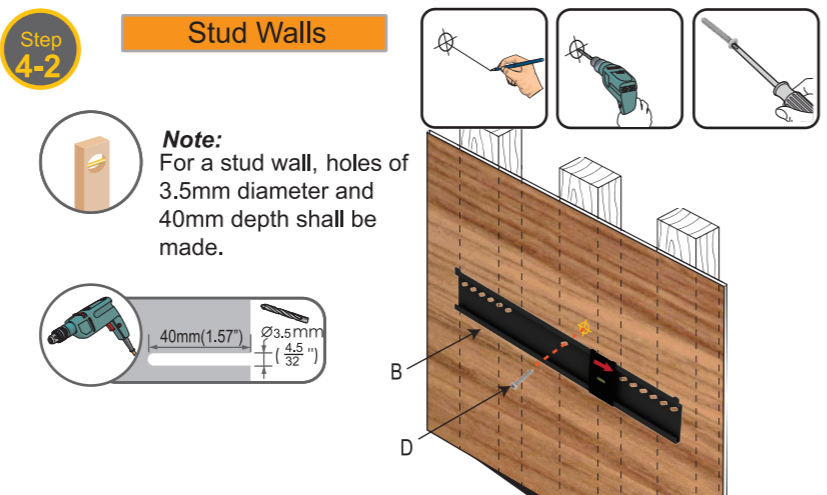
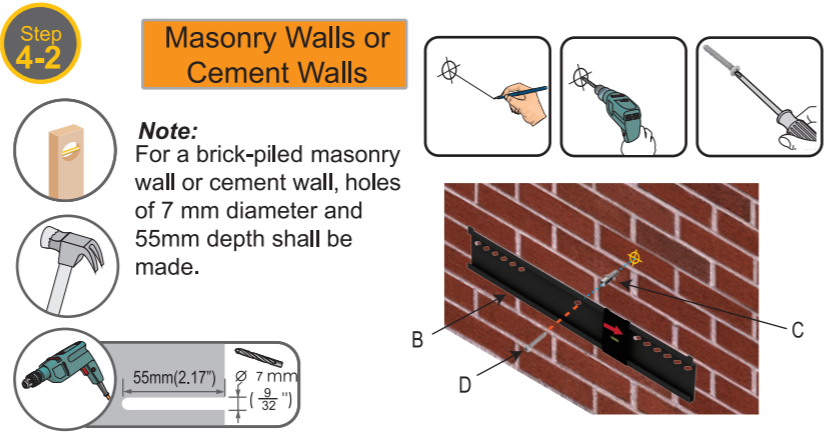

Lock

Uninstall

